

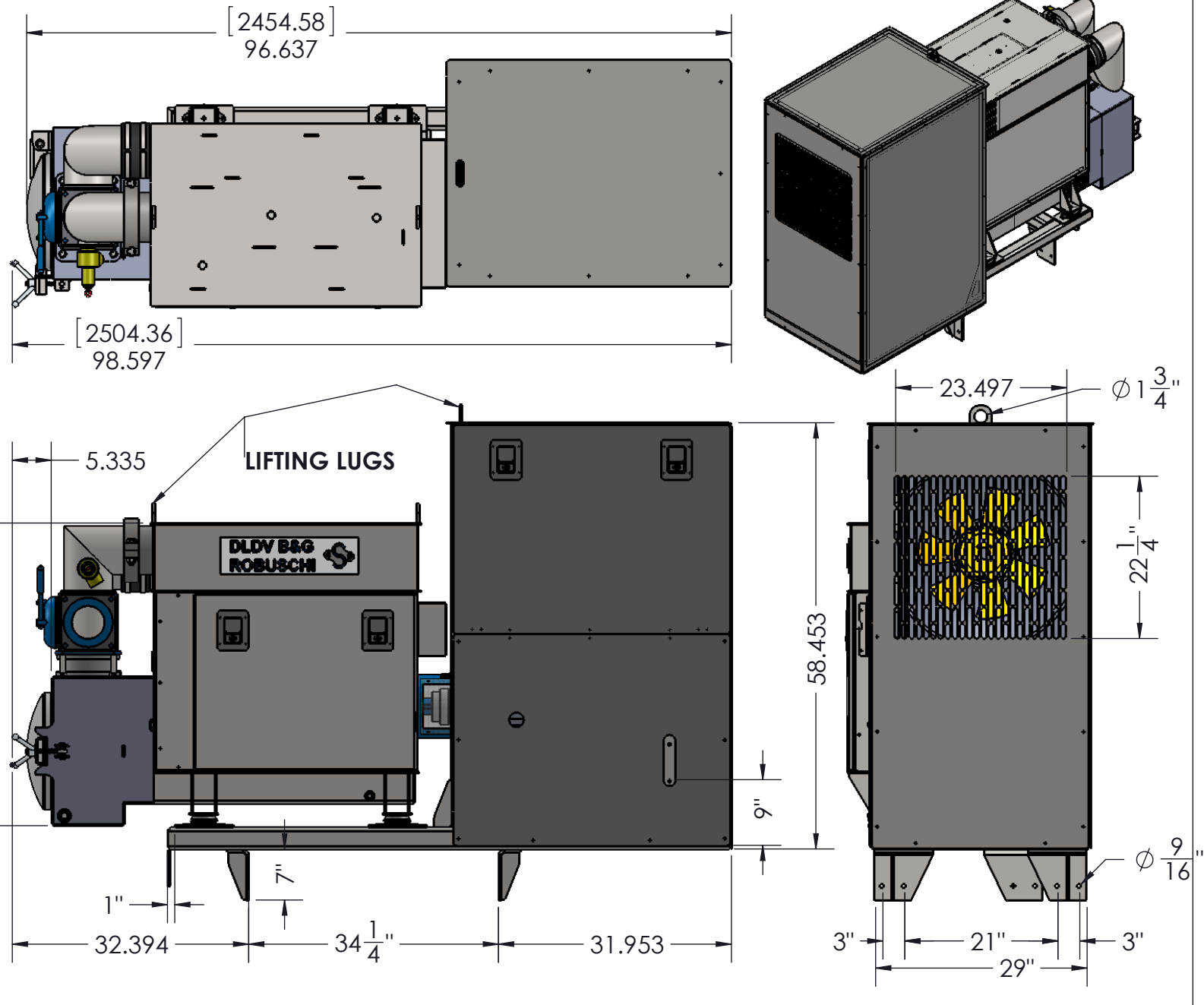

**1600 CFM ( 28" Hg )  
BLOWER RB-DV-85  
With Hydraulic System**



- NOTES:**
1. ELEMENT No 81-1040 (M 562-421)
  2. HYDRAULIC MOTOR SCM-064-SAE.
  3. COOLER-ULHC-033.
  4. HYDRAULIC TANK-50 Gallon.

 <b>SURPRESSEUR 4S</b>	TOLÉRANCES GÉNÉRALES, SAUF INDICATION CONTRAIRE GENERAL TOLERANCES, UNLESS NOTED OTHERWISE	CE DESSIN EST LA PROPRIÉTÉ EXCLUSIVE DE SURPRESSEUR 4S THIS DRAWING IS THE EXCLUSIVE PROPERTY OF SURPRESSEUR 4S		DESCRIPTION : DLDV-85_HM & HR GENERAL ARRANGEMENT	
	IMPÉRIAL / MÉTRIQUE FRACTION: ±1/16" ±2.0mm DECIMAL/DECIMAL: ±0.015" ±0.5mm ANGULAIRE/ANGLE: ±1° ±1°	CONCEPTEUR / DESIGNER V.B. DATE 1.11.2015 VÉRIFIÉ PAR / CHECKED BY D.L. DATE 3.11.2015 ECHELLE / SCALE: 1:32 FORMAT A			
	101, DE L'ISÈRE CANDIAC, QC, CANADA JSR 0M6, TEL.: 450-619-6363, FAX.: 450-619-9696			DESSIN NO / DRAWING NO : <b>DLDV85FC_HM_&amp;_HR_GA</b>	FEUILLE SHEET 1/4 Rev 1

Référence / References : --	Traiter par / Process by : ASSE	Poids / Weights : 2000 LBS
-----------------------------	---------------------------------	----------------------------