

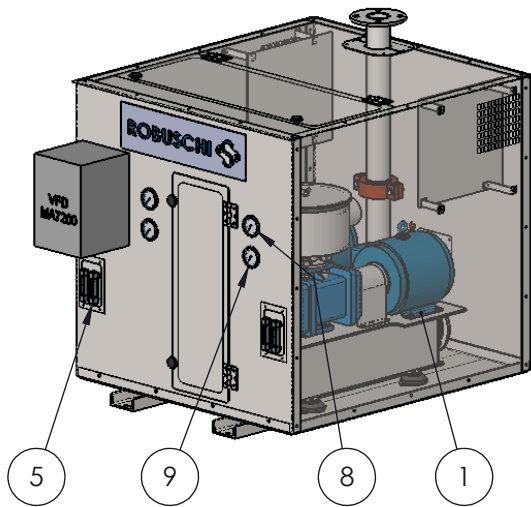

ITEM NO.	PART NUMBER	DESCRIPTION	QTY.
1	AE_EL15_1P_DD_DP	ENCEINTE ACOUSTIQUE/ACOUSTICAL ENCLOSURE 38" X 42"	1
2	EL15-1P-5HP_DD_DP	ROBOX-1P/RBS-15/184T-5HP	2
3	PIPING_1P_DD_DP	TUYAUTERIE/PIPING DN 2 1/2"	1
4	1050-0000MZ-2inc.	SOUPAPE DE SÉCURITÉ/PRESSURE RELIEF VALVE	1
5	B-1556-1X39	UISEUR L'HUILE/OIL LEVEL	4
6	518	CLAPET ANTI-RETOUR/CHECK VALVE - 2 1/2"-FLEXI-HINGE 518	2
7	MA7200	VFD	1
8	-32-0 po.-H2O	MANOMÈTRE/GAUGE	2
9	0+15 PSIG	MANOMÈTRE/GAUGE	2
10	SPOOL_DN2.5_22LG_GLV	SPOOL_DN 2 1/2" _22LG_GLV	1

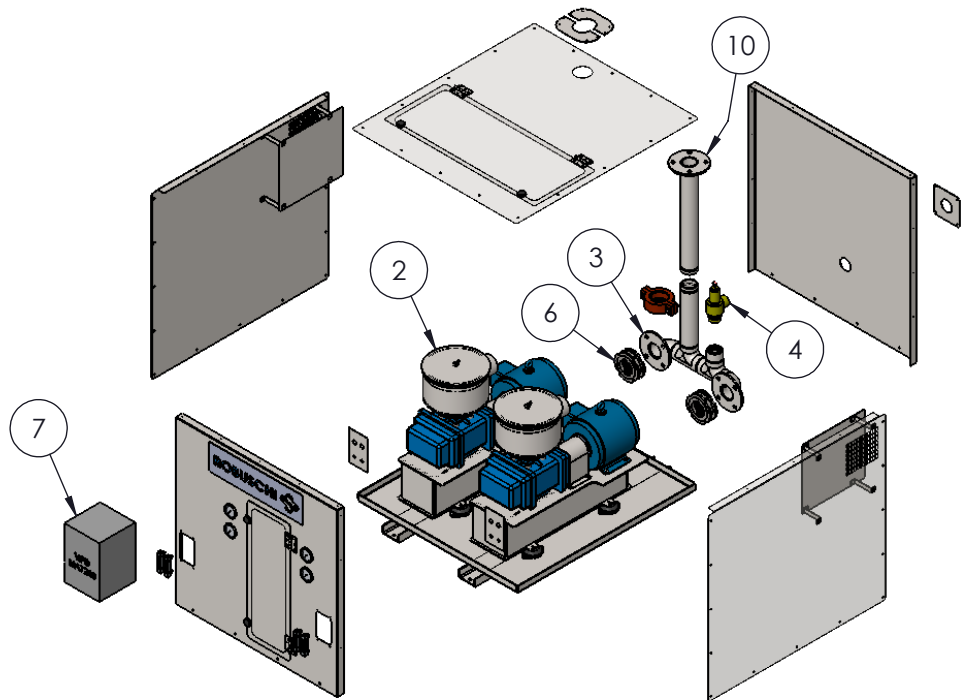

ISO VIEW



EXPLODED VIEW

 SURPRESSEUR 4S	TOLÉRANCES GÉNÉRALES, SAUF INDICATION CONTRAIRE GENERAL TOLERANCES, UNLESS NOTED OTHERWISE	CE DESSIN EST LA PROPRIÉTÉ EXCLUSIVE DE SURPRESSEUR 4S THIS DRAWING IS THE EXCLUSIVE PROPERTY OF SURPRESSEUR 4S		Description : ROBOX-1P EL15_1P	
	IMPÉRIAL MÉTRIQUE FRACTION: ±1/16" ±2.0mm DECIMAL/DECIMAL: ±0.015" ±0.5mm ANGULAIRE/ANGLE: ±1° ±1°	CONCEPTEUR / DESIGNER V.B. DATE 2014/12/19	VERIFIÉ PAR / CHECKED BY D.L. DATE 2014/12/19	ECHELLE / SCALE: 1:16 FORMAT A	-- --
	101, DE L'ISERE CANDIAC, QUÉ. CANADA JSR 0M6, TEL.: 450-619-6363, FAX.: 450-619-9696	DESSIN NO / DRAWING NO : ES_EL15_1P_DD_DP		FEUILLE SHEET 1/4	Rev 0

Référence / References : --

Trailer par / ASSE
Process by :

Poids / Weights : 1027 LBS